

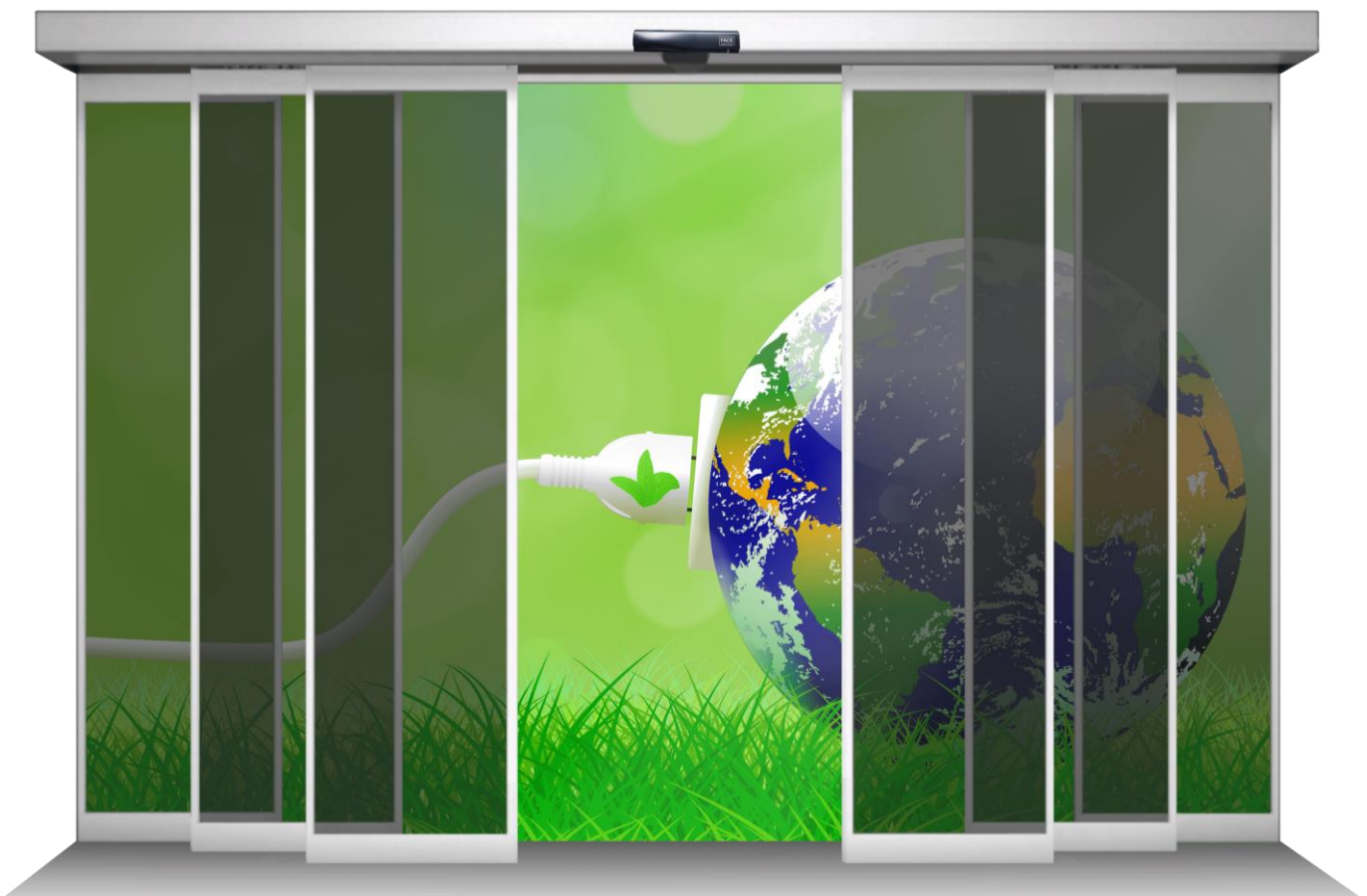

THE NEW GREEN GENERATION OF PEDESTRIAN DOORS AUTOMATIONS

Driven only by direct-drive Brushless motors with extended range power supply 100-240 V (50/60 Hz) Switch Mode technology



THE FIRST REAL ENERGY SAVING AUTOMATIONS THAT REDUCE ENERGY CONSUMPTION BY OVER 50%



SLIDING DOOR AUTOMATIONS - ADVANCED VERSION

DIRECT DRIVE - BRUSHLESS MOTORS



ADVANCED DIRECT DRIVE BRUSHLESS MOTOR made in FACE: The Brushless motor works in direct drive on the transmission belt without the use of a gearbox. This epochal technological evolution that substitutes the obsolete and less performant DC gearmotors, with brush commutation, allows the great following results.

- ✓ **Increased efficiency and reduction of electricity consumption:** 30% obtained by the Brushless motor and 30% by the absence of the gearbox.
- ✓ **Elimination of maintenance costs that derive from wear:** The Brushless motor operates at a low speed (approximately 600 rpm) so it can be classified as a type of motor with no wear and its service life is almost ten times longer than a traditional DC motor with brushes. The elimination of the gearbox represents the greatest optimization since what is not there can neither be worn nor broken.
- ✓ **Silence:** The absence of brushes makes the motor very silent and the elimination of the gearbox improves efficiency even more.
- ✓ **Functional and dimensional compactness:** The motor is very compact, small and functional. The exclusive and patented positioning of the hall effect position sensor inside the rear shell guarantees excellent protection from accidental impacts. The system is thus very robust, essential and suitable for intensive use. Furthermore, the position of the sensor - that is also a temperature sensor, guarantees effective protection against overheating during operation, which could damage the motor itself.
- ✓ **Warranty: FACE** invests a lot in technological evolution and considers it as the unique way to create more eco-compatible products. This allows to guarantee a **5-year warranty on all models of Brushless motors**. The more we stretch our products life, the less trash we produce.

ELECTRONIC CONTROL UNIT - ADVANCED VERSION

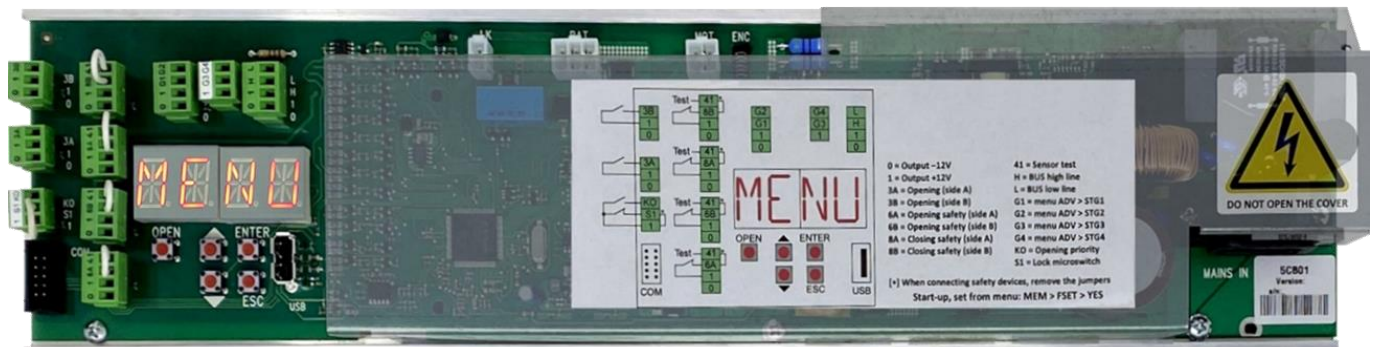

The new generation **ADVANCED ELECTRONIC CONTROL UNIT made in FACE** has a basic platform with high expansion potential and contributes to increase the **energy efficiency** of the entire system.

Find below the distinctive features:

- ✓ **Extended range power supply 100-240 V (50/60 Hz) with Switch Mode Technology** that guarantees **15%** increase in energy efficiency and subsequent reduction of power consumption.
- ✓ **Alphanumeric Display** that allows to read diagnostic information and to modify the parameters directly from the electronic board keypad.
- ✓ **Factory setting** set in standard mode that satisfy most applications and make the door operational without the need of any further adjustment.
- ✓ **Customizable and editable parameters** to satisfy all specific needs.
- ✓ **Configurable input/output terminals** with a wide range of functionalities for every installation need.
- ✓ **Separated terminals** for each safety and control accessory.
- ✓ **USB memory card input** that allows to update the firmware (available on **FACE** website), upload and download functional parameters and download information useful for diagnostic.
- ✓ **Remote control Interface** both for NETRC system supplied by **FACE**, and for the integration with any customized remote-control system.

SLIDING AUTOMATIONS - EMERGENCY VERSION

Redundant that comply to the European standard EN16005 (DIN18650)

FOR ESCAPE ROUTES AND EMERGENCY EXITS

BRUSHLESS MOTOR “FACE 2 in 1” WITH DOUBLE WINDING
AND DIRECT DRIVE



EMERGENCY DIRECT DRIVE BRUSHLESS MOTOR made in FACE:

“**FACE 2 in 1**” patented and exclusive Brushless motor is a unique solution. It is characterized by having two windings that are in the same mechanic case of the **ADVANCED** model and act as two completely independent motors. As the **ADVANCED** model, also the **EMERGENCY** model operates in direct drive on the transmission belt without the use of a gearbox. This extraordinary technological evolution substitutes the traditional, obsolete and less performing DC gearbox motors with brush commutation and allows the great following results:

- ✓ **Periodic self-test:** The electronic control unit carries out periodic self-tests on both windings in order to guarantee the correct functioning of the automation even in emergency and power failure conditions.
- ✓ **Sensorless opening:** In case of sensor failure, the emergency opening occurs in sensorless modality. This unique and distinctive **FACE** solution is designed to guarantee greater reliability and safety of the entire system in case of emergency and electric failure.
- ✓ **Increased efficiency and reduction of electricity consumption:** 30% obtained by the Brushless motor and 30% by the absence of the gearbox.
- ✓ **Elimination of maintenance costs that derive from wear:** The Brushless motor operates at a low speed (approximately 600 rpm) so it can be classified as a type of motor with no wear and its service life is almost ten times longer than a traditional DC motor with brushes. The elimination of the gearbox represents the greatest optimization since what is not there can neither be worn nor broken.
- ✓ **Silence:** The absence of brushes makes the motor very silent and the elimination of the gearbox improves efficiency even more.
- ✓ **Functional and dimensional compactness:** The motor is very compact, small and functional. The exclusive and patented positioning of the hall effect position sensor inside the rear shell guarantees excellent protection from accidental impacts. The system is thus very robust, essential and suitable for intensive use. Furthermore, the position of the sensor - that is also a temperature sensor, guarantees effective protection against overheating during operation, which could damage the motor itself.
- ✓ **Warranty: FACE** invests a lot in technological evolution and considers it as the unique way to create more eco-compatible products. This allows to guarantee a **5-year warranty on all models of Brushless motors**. The more we stretch our products life, the less trash we produce.

ELECTRONIC CONTROL UNIT - EMERGENCY VERSION (REDUNDANT) WITH ADDITIONAL EMERGENCY BOARD



The **EMERGENCY ELECTRONIC CONTROL UNIT made in FACE** has the same technological platform of the **ADVANCED CONTROL UNIT**, with the addition of an independent control board. It is specifically designed to comply with the functional and performance requirements of European standards for emergency exits and escape routes to guarantee the immediate recognition of anomalies that might compromise the correct opening of the door, commanding the emergency opening. Find below the distinctive characteristics:

- ✓ **The additional emergency board** has its own microcontroller and is completely independent from the main board. The two boards communicate through a CAN bus communication.
- ✓ **Incumbrance space optimization** the emergency board is installed on the main board, keeping the overall dimensions of the entire electronic control unchanged as in the **ADVANCED** version.
- ✓ **The emergency opening sensor**, intrinsically safe, is installed in the direction of the escape route and is linked to the emergency board.
- ✓ **Emergency opening.** On the occurrence of a critical condition that requires the immediate emergency opening of the door, the main board, or the additional emergency board, autonomously pilots one of the two motor windings to guarantee the opening of the doors depending on the detected condition.
- ✓ **Extended range power supply 100-240 V (50/60 Hz) with Switch Mode Technology** that guarantees 15% increase in energy efficiency and subsequent reduction of power consumption.
- ✓ **Alphanumeric Display** that allows to read diagnostic information and to modify the parameters directly from the electronic board keypad.
- ✓ **Factory setting** set in standard mode that satisfy most applications and make the door operational without the need of any further adjustment.
- ✓ **Customizable and editable parameters** to satisfy all specific needs.
- ✓ **Configurable input/output terminals** with a wide range of functionalities for every installation need.
- ✓ **Separated terminals** for each safety and control accessory.
- ✓ **USB memory card input** that allows to update the firmware (available on **FACE** website), upload and download functional parameters and download information useful for diagnostic.
- ✓ **Remote control Interface** both for NETRC system supplied by **FACE**, and for the integration with any customized remote-control system.

TELESCOPIC SLIDING AUTOMATION

The **TELESCOPIC automation made in FACE**, in the **ADVANCED** and **EMERGENCY** version, is a real revolution of the technique applied by now to this specific type of automation. **FACE** designed a series of innovative and unique mechanical solutions, which allow an extraordinary simplification of installation and maintenance.

The two most innovative and significant technical solutions are listed below:

- ✓ **Suspended Sliding Guide for fast leaves.** The fast leaves slide on a suspended rail connected to the box profile by modular support brackets with front hooking. This exclusive and patented solution allows easy access to the carriages of the slow leaves during installation and maintenance, simplifying and speeding up the installation and adjustment of the leaves, halving working time and labour costs.

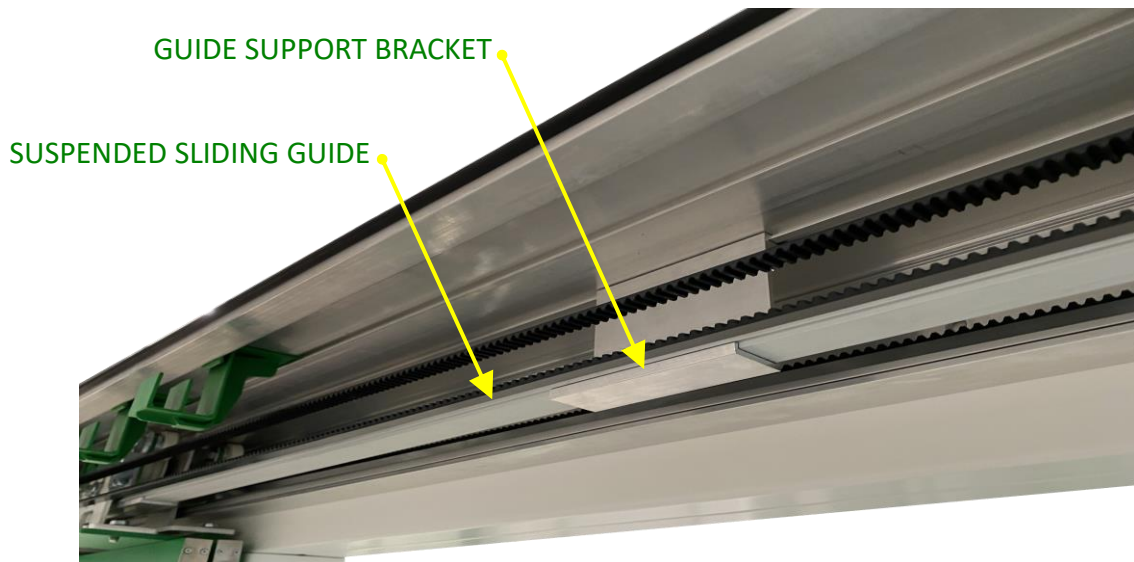

- ✓ **Double-pulley transmission system with independent rotation.** The two transmission belt pulleys for slow and fast leaves, positioned on the opposite side of the motor, rotate in an independent or synchronized movement. This exclusive and patented solution allows to obtain extraordinary benefits selecting the two operating status modes as below:
 - Status 1 – Independent rotation, unlocked system.** During the installation, maintenance and replacement of the leaves, it allows a quick fastening of slow and fast doors to their respective carriages in the position of the respective sliding guide that is most comfortable and easy for the installer.
 - Status 2 – Synchronized rotation, system locked.** After fixing the slow and fast leaves to their respective carriages in the position of the sliding guide that is most comfortable and easy for the installer, both the slow and fast leaves are simply pushed by hand in the open-door position. Locking the two pulleys with the two frontal grub screws of the fast pulley, the perfectly synchronized movement of the leaves is obtained.

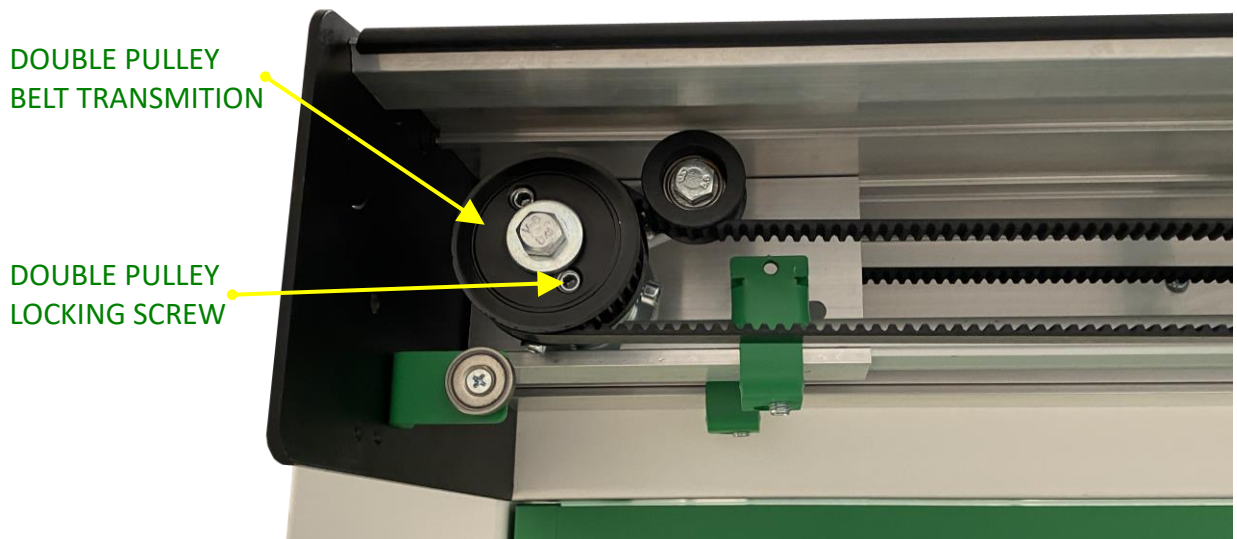

SENSOR FIXING DEVICE

The exclusive and patented **SENSORS FIXING DEVICE** made in **FACE** with quick coupling and release thanks to the magnets on the rear slide, revolutionizes the traditional way of installing sensors.

This innovative system offers the following advantages:

- ✓ **It is no longer necessary to drill the automation cover.** The sensor fixing device is fixed directly on the main beam through a simple and quick coupling clip system **FACE**.
- ✓ **The adjustment of the sensors can be done in their real operating position.** The connections to the electronic control terminal blocks can be made in a more practical and faster way. The great advantage is that while connecting and adjusting, it is possible to read the feedback on the display of the control board that is not hidden by the automation cover as in traditional systems.
- ✓ **Faster and less expensive maintenance operations.** To remove and refit the automation cover, it is no longer necessary to disconnect the sensor but simply to lower and raise the fixing support.
- ✓ **Modular sensor fixing system.** The system is designed to support the sensors of the four main brands on the market.



SUPERCAPACITOR OPENING DEVICE

The exclusive and patented **SUPERCAPACITOR OPENING DEVICES** made in **FACE**, are **ECO-FRIENDLY** devices for automatic opening in the event of a power failure, designed using **SUPERCAPACITOR** technology, in place of the old devices with **LEAD BATTERIES** used in both redundant sliding automations and standard ones.



FACE AUTOMATIONS HAVE BECOME:



This extraordinary step forward to the **ECOLOGICAL TRANSITION** has been awarded with the:

R+T INNOVATION **GOLD** AWARD 2021



Landesmesse Stuttgart GmbH Germania

The following comparative table lists the extraordinary advantages obtained with this innovative and unique system:

Comparison of devices for automatic opening in the event of a power failure New SUPERCAPACITOR technology > Old BATTERY technology		
PERFORMANCE AND TECHNICAL SPECIFICATIONS	SUPERCAPACITOR	BATTERIES
Product lifespan	Up to 20 years	3 years
TÜV Thüringen certification: EN16005 DIN18650 AutSchR	YES	YES
Limit to number of discharge cycles	NO	YES
Sensitivity to temperature in terms of charge	NO	YES
Sensitivity to temperature in terms of product lifespan	NO	YES
Storage requisites (self-discharge)	NO	YES
Toxic chemical products / heavy metals	NO	YES
Hazardous waste	NO	YES
Waste disposal costs	Standard	Very expensive
Weight (handling, shipment, installation)	Lightweight	Heavy
Cost of shipment via land or sea	Standard	Very expensive
Cost of shipment by air	Standard	Extremely expensive
Transportation restrictions	NO	YES
Sale price (BATTERIES base reference price = 100)	200 (+ 100%)	100
Cost over 20 years	200	666 (+233%)
Savings over 20 years (excluding replacement costs)	- 466 (- 70%)	---

SWING AUTOMATIONS SW80

BRUSHLESS MOTOR WITH GEARBOX

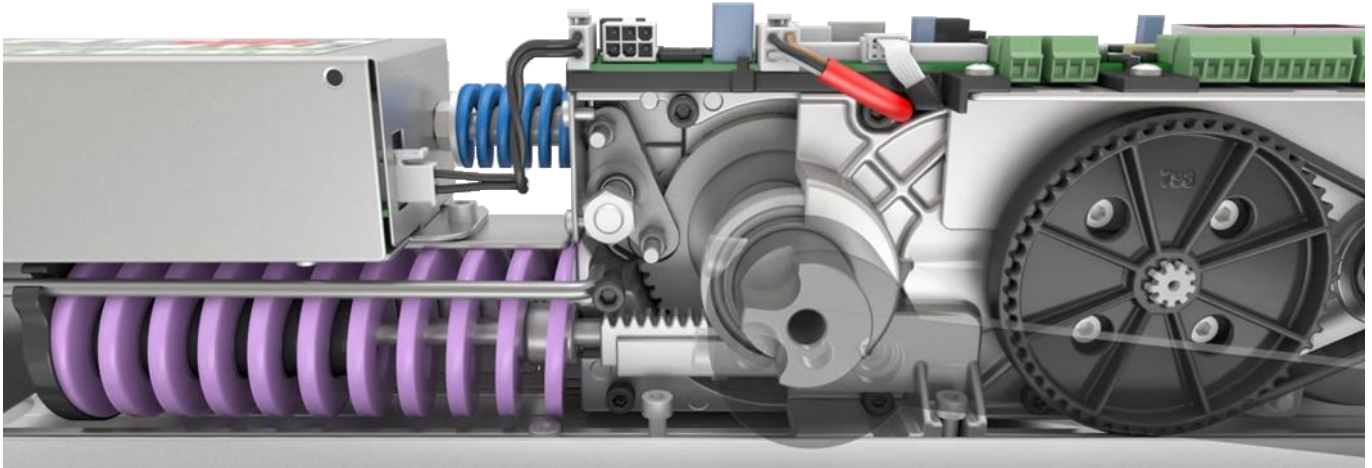

FACE swing door automations are performing and compact, use **Brushless motors made in FACE** instead of traditional obsolete DC motors with less performing brush commutation, and are coupled to a reduction unit designed to be reliable, compact and silent.

Below are the main distinctive features:

BRUSHLESS MOTOR

- ✓ **Increased efficiency and performance**, reducing electricity consumption of 30%.
- ✓ **Elimination of maintenance costs that derive from wear:** The Brushless motor operates at a low speed (approximately 600 rpm) so it can be classified as a type of motor with no wear and its service life is almost ten times longer than a traditional DC motor with brushes.
- ✓ **Silence:** The absence of brushes makes the motor very silent.
- ✓ **Functional and dimensional compactness:** The motor is very compact, small and functional. The exclusive and patented positioning of the hall effect position sensor inside the rear shell guarantees excellent protection from accidental impacts that might break it. The system is thus very robust, essential and suitable for intensive use.
- ✓ **Warranty:** FACE invests a lot in technological evolution and it considers it as the unique way to create more eco-compatible products. This allows to guarantee **5 years of warranty on all models of Brushless motors**. The more we stretch our products life, the less trash we produce.

GEARBOX UNIT

- ✓ **High force for heavy doors and strong wind conditions, considerable silence** thanks to the efficient transmission of the rotation force from the Brushless motor to the gearbox unit by means of a belt. The reduction gear system is designed to ensure maximum performance and absolute reversibility.
- ✓ **TWO SPRINGS** allow the door closure even in absence of electricity.
 - The big spring** works during the entire manoeuvre of the door and guarantees its mechanical closure with a harmonious and safe movement.
 - The small spring** works only in the last 6° of closure in order to give more strength in the final phase of the race, overcoming any resistance caused by locks or wind.

ELECTRONIC CONTROL UNIT - SWING AUTOMATION SW80



The new generation **ELECTRONIC CONTROL UNIT made in FACE** has a basic platform with high expansion potential and contributes to increase the **energy efficiency** of the entire system.

Find below the distinctive features:

- ✓ **Extended range power supply 100-240 V (50/60 Hz)** with **Switch Mode Technology** that guarantees **15%** increase in energy efficiency and subsequent reduction of power consumption.
- ✓ **Alphanumeric Display** that allows to read diagnostic information and to modify the parameters directly from the electronic board keypad.
- ✓ **Factory setting** set in standard mode that satisfy most applications and make the door operational without the need of any further adjustment.
- ✓ **Customizable and editable parameters** to satisfy all specific needs.
- ✓ **Configurable input/output terminals** with a wide range of functionalities for every installation need.
- ✓ **Separated terminals** for each safety and control accessory.
- ✓ **USB memory card input** that allows to update the firmware (available on **FACE** website), upload and download functional parameters and download information useful for diagnostic.
- ✓ **Remote control Interface** both for NETRC system supplied by **FACE**, and for the integration with any customized remote-control system.

SWING AUTOMATIONS SW2 E SW5

BRUSHLESS MOTOR WITH GEARBOX

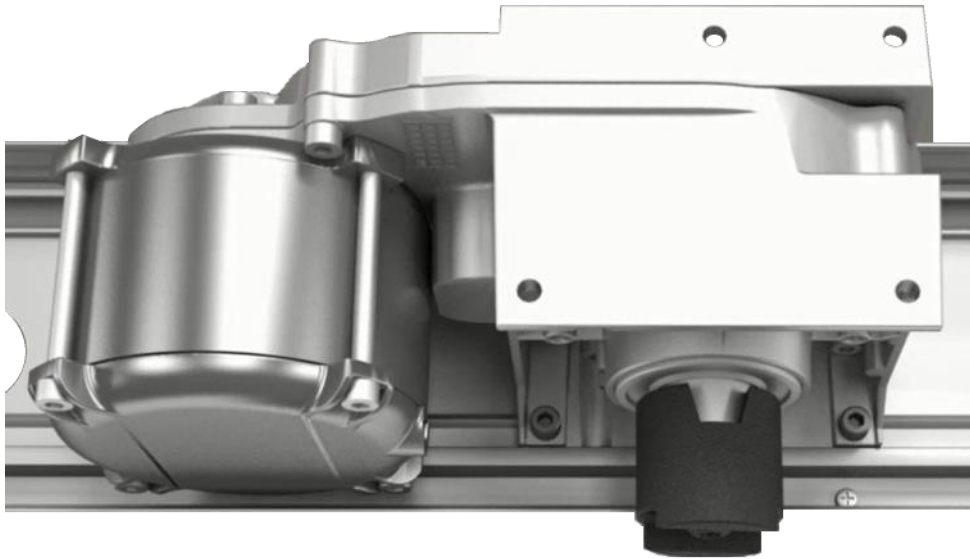

BRUSHLESS MOTOR

- ✓ **Increased efficiency and performance**, reducing electricity consumption of 30%.
- ✓ **Elimination of maintenance costs that derive from wear:** The Brushless motor operates at a low speed (approximately 600 rpm) so it can be classified as a type of motor with no wear and its service life is almost ten times longer than a traditional DC motor with brushes.
- ✓ **Silence:** The absence of brushes makes the motor very silent.
- ✓ **Functional and dimensional compactness:** The motor is very compact, small and functional. The exclusive and patented positioning of the hall-effect position sensor inside the rear shell guarantees excellent protection from accidental impacts. The system is thus very robust, essential and suitable for intensive use.
- ✓ **Warranty:** FACE invests a lot in technological evolution considering it as the unique way to create more eco-compatible products. This allows to guarantee **5 years of warranty on all models of Brushless motors**. The more we stretch our products life, the less trash we produce.

GEARBOX UNIT

- ✓ **Compact size, suitable for intensive use.** It is housed in a double case aluminium shell on which the Brushless motor is fixed and from which the pin connected to the wing movement arm comes out. The reduction gear system is designed to guarantee maximum performance and absolute reversibility.

ELECTRONIC CONTROL UNIT - SWING AUTOMATIONS SW2 E SW5

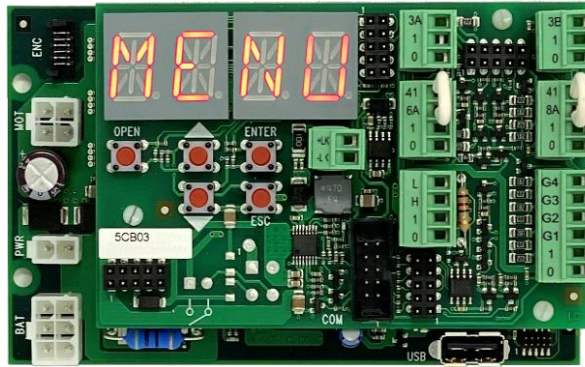

The new generation **ELECTRONIC CONTROL UNIT made in FACE** has a basic platform with high expansion potential and contributes to increase the **energy efficiency** of the entire system.

Find below the distinctive features:

- ✓ **Extended range power supply 100-240 V (50/60 Hz)** with **Switch Mode Technology** that guarantees **15%** increase in energy efficiency and subsequent reduction of power consumption.
- ✓ **Alphanumeric Display** that allows to read diagnostic information and to modify the parameters directly from the electronic board keypad.
- ✓ **Factory setting** set in standard mode that satisfy most applications and make the door operational without the need of any further adjustment.
- ✓ **Customizable and editable parameters** to satisfy all specific needs.
- ✓ **Configurable input/output terminals** with a wide range of functionalities for every installation need.
- ✓ **Separated terminals** for each safety and control accessory.
- ✓ **USB memory card input** that allows to update the firmware (available on **FACE** website), upload and download functional parameters and download diagnostic information.
- ✓ **Remote control Interface** both for NETRC system supplied by **FACE** and for the integration with any customized remote-control system.

ELECTRONIC FUNCTION SELECTOR FSD5 With Transponder Key and Bluetooth

FSD5 Function selector combines the harmony and elegance of its shape and the aquamarine green colour with advanced technological contents and is designed to obtain full control of the automations functions to which it is connected.

The compact size (width 43 mm, high 143 mm, depth 17 mm) allows it to be fixed on thin frames and vertical uprights and to look good in prestigious environments.

FSD5 is equipped with Bluetooth and NFC transmission systems that allow remote interaction between the selector and the electronic control of the automation via smartphone and after installing **FACE** applications:

FACE PRC Professional Remote Control

FACE URC User Remote Control

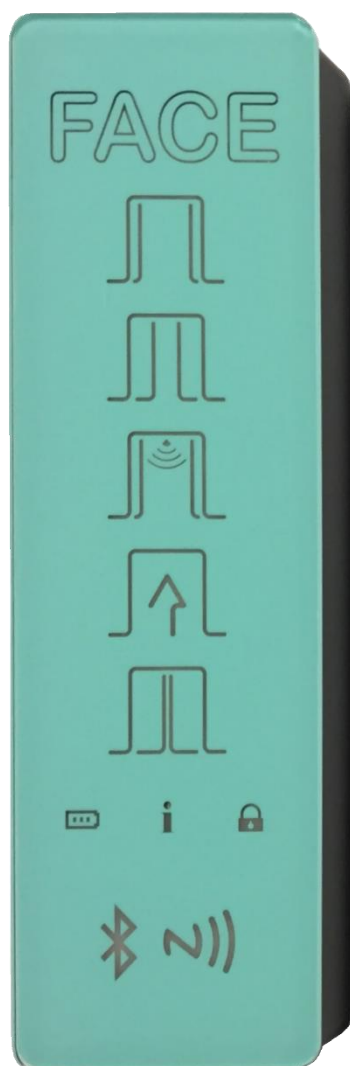

FACE URC (User Remote Control)

FACE URC smartphone application is developed for the end user of the **FACE** automations and allows to perform the following operations:

- ✓ Change the status of **FSD5** function selector.
- ✓ Give the priority opening command.
- ✓ Download the diagnostics to be sent to your service centre via WhatsApp or e-mail for maintenance.
- ✓ Use the smartphone as a badge.



FACE PRC (Professional Remote Control)

FACE PRC smartphone application is developed for the installer/maintainer of **FACE** automations and allows to perform the following operations:

- ✓ Set and modify the parameters of the connected automations.
- ✓ Download the parameters of an automatic door and upload them on other installations that require the same settings.
- ✓ Download the diagnostic for maintenance, read the alarms, read the number of the cycles performed.
- ✓ The downloaded parameters can be sent to multiple recipients for consultation via WhatsApp and e-mail.



ELECTRONIC FUNCTION SELECTOR FSD6 With Transponder Key

FSD6 function selector is available in four different standard colours or in a personalized colour customized and exclusively designed. Further customizations are possible as detailed in the specific list.

The **FSD6** function selector is designed to have the full function control on the automations combining the harmony and elegance of its shape and colours with high technological contents.

FSD6 BK



FSD6 AV



FSD6 GR



FSD6 OR





- ✓ **The activation of the function selector can be restricted** to authorized people with the use of a code.
- ✓ **Its compact size** (Width 42 mm, Height 140 mm, Depth 15 mm) allow to fix it on thin profiles and vertical uprights.

RANGE OF SLIDING AUTOMATIONS

SLIDING AUTOMATIONS	MAXIMUM WEIGHT		SERVICE CLASS INTERMITTENCE	SECTION DIMENSIONS
	1 leaf	2 leaves		
SL3L LIGHT	1x70 kg	2x50 kg 2x60 kg	Continuous operation S3 = 100% S3 = 80%	
SL4A ADVANCED SL4E EMERGENCY	1x100 kg	2x90 kg	Continuous operation S3 = 100%	
SL5A ADVANCED SL5E EMERGENCY SL5H HEAVY	1x140 kg 1x140 kg 1x180 kg	2x120 kg 2x120 kg 2x150 kg	Continuous operation S3 = 100% S3 = 100% Intense operation S3 = 60%	
SL6A ADVANCED SL6E EMERGENCY SL6H HEAVY SL6B BIG	1x140 kg 1x140 kg 1x180 kg 1x400 kg	2x120 kg 2x120 kg 2x150 kg 2x250 kg	Continuous operation S3 = 100% S3 = 100% S3 = 60% S3 = 60%	
HERMETIC SL6HA ADVANCED SL6HB BIG	1x100 kg 1x200 kg		Intense operation S3 = 60% S3 = 60%	
TELESCOPIC SLTA ADVANCED SLTE EMERGENCY SLDAA ADVANCED SLDEE EMERGENCY	2x100 kg 2x100 kg 2x100 kg 2x100 kg	4x70 kg 4x70 kg	Continuous operation S3 = 100% S3 = 100% Continuous operation S3 = 100% S3 = 100%	

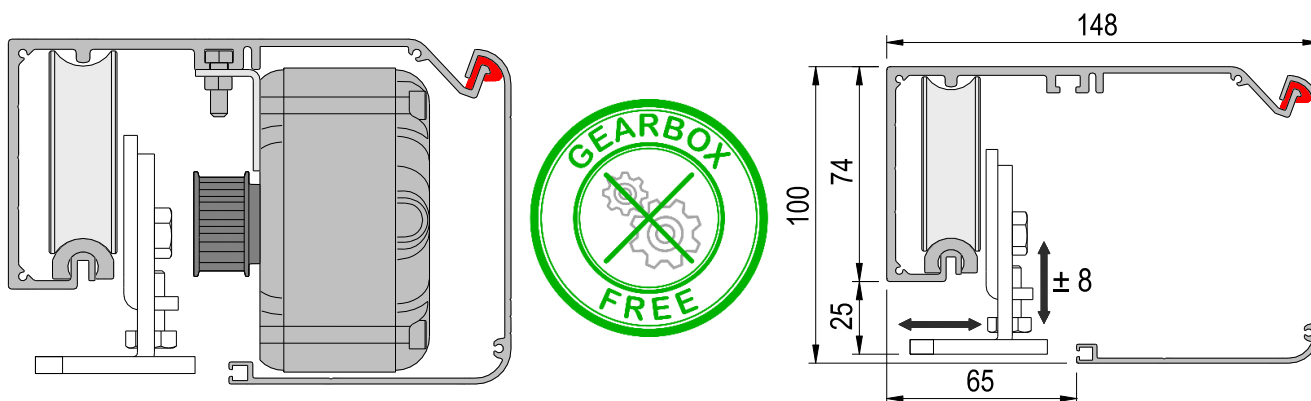



TECHNICAL SPECIFICATIONS FOR SL3 AUTOMATIONS

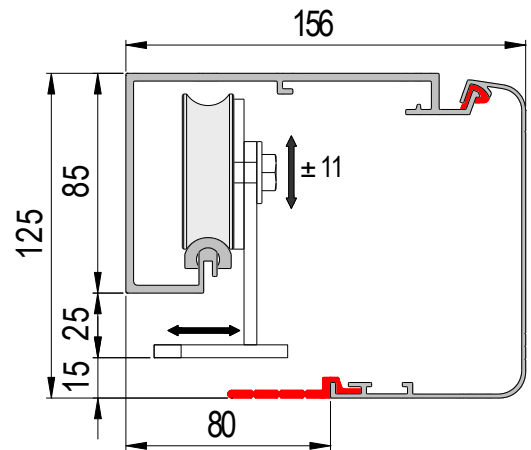
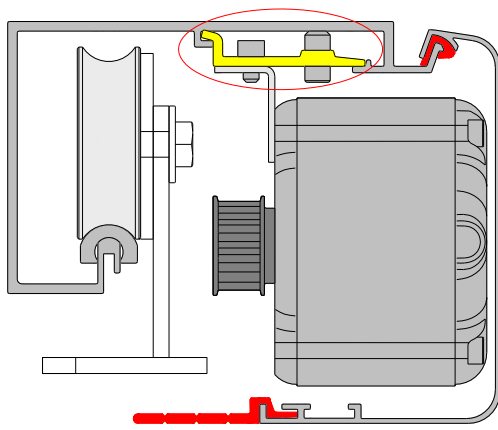

Series	SL3L
Model	LIGHT
Use	Sliding automatic doors
Reference standards	EN 16005
Dimensions	100 x 148 x 6600 mm
Max. load	70 kg 1 wing (S3 = 100%) 2x50 kg 2 wings (S3 = 100%) / 2x60 kg 2 wings (S3 = 80%)
Max. speed	0.8 m/s 1 wing 1.6 m/s 2 wings
Service class Intermittence	Continuous operation S3 = 100% (2x50 kg) / S3 = 80% (2x60 kg)
Internal durability test	
Power supply	100–240 V 50/60 Hz
Rated power	60W
Stand-by	8W
Rated load	80 N
Degree of protection	IP 20
Operating temperature	 -15 °C +50 °C
Parameter adjustment	Buttons and display
Accessory output	12 VDC (1 A max)
Firmware update	USB standard









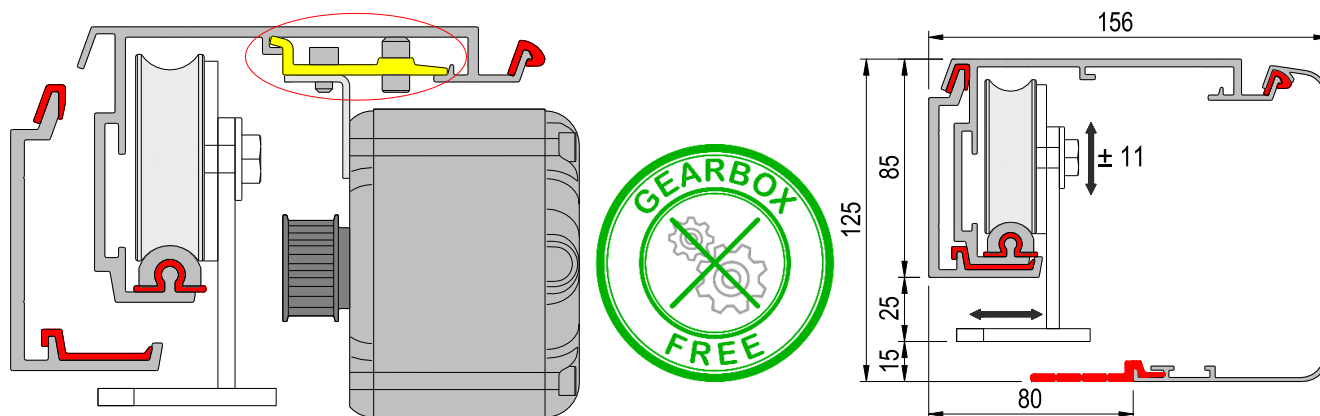



TECHNICAL SPECIFICATIONS FOR SL4 AUTOMATIONS



Series	SL4A	SL4E
Model	ADVANCED	EMERGENCY
Use	Sliding automatic doors	Sliding automatic doors for escape routes and emergency exits
Type approval	 <p>Type tested DIN EN 16005, DIN 18650-1/2</p> <ul style="list-style-type: none"> • open and close safe <p>ID P-4070/15</p>	 <p>Type tested DIN EN 16005, DIN 18650-1/2, AutSchR</p> <ul style="list-style-type: none"> • escape route safe • open and close safe <p>ID P-4071/15</p>
Dimensions	125 x 156 x 6600 mm	125 x 156 x 6600 mm
Max. load	100 kg 1 wing 2x90 kg 2 wings	100 kg 1 wing 2x90 kg 2 wings
Max. speed	0.8 m/s 1 wing 1.6 m/s 2 wings	0.8 m/s 1 wing 1.6 m/s 2 wings
Service class Intermittence	Continuous operation S3 = 100%	Continuous operation S3 = 100%
Internal durability test		
Power supply	100–240 V 50/60 Hz	100–240 V 50/60 Hz
Rated power	70W	70W
Stand-by	10W	10W
Rated load	150 N	150 N
Degree of protection	IP 20	IP 20
Operating temperature		
Parameter adjustment	Buttons and display	Buttons and display
Accessory output	12 VDC (1 A max)	12 VDC (1 A max)
Firmware update	USB standard	USB standard

TECHNICAL SPECIFICATIONS FOR SL5 AUTOMATIONS



Series	SL5A	SL5E	SL5H
Model	ADVANCED	EMERGENCY	HEAVY
Use	Sliding automatic doors	Sliding automatic doors for escape routes and emergency exits	Heavy sliding automatic doors
Type approval	 <p>Type tested DIN EN 16005, DIN 18650-1/2</p> <ul style="list-style-type: none"> • open and close safe <p>ID P-4070/15</p>	 <p>Type tested DIN EN 16005, DIN 18650-1/2, AutSchR</p> <ul style="list-style-type: none"> • escape route safe • open and close safe <p>ID P-4071/15</p>	
Dimensions	125 x 156 x 6600 mm	125 x 156 x 6600 mm	125 x 156 x 6600 mm
Max. load	140 kg 1 wing 2x120 kg 2 wings	140 kg 1 wing 2x120 kg 2 wings	180 kg 1 wing 2x150 kg 2 wings
Max. speed	0.8 m/s 1 wing 1.6 m/s 2 wings	0.8 m/s 1 wing 1.6 m/s 2 wings	0.6 m/s 1 wing 1.2 m/s 2 wings
Service class Intermittence	Continuous operation S3 = 100%	Continuous operation S3 = 100%	Intense operation S3 = 60%
Internal durability test			
Power supply	100–240 V 50/60 Hz	100–240 V 50/60 Hz	100–240 V 50/60 Hz
Power	70W	70W	70W
Stand-by	10W	10W	10W
Rated load	150 N	150 N	150 N
Degree of protection	IP 20	IP 20	IP 20
Operating temperature	 -15 °C  +50 °C	 -15 °C  +50 °C	 -15 °C  +50 °C
Parameter adjustment	Buttons and display	Buttons and display	Buttons and display
Accessory output	12 VDC (1 A max)	12 VDC (1 A max)	12 VDC (1 A max)
Firmware update	USB standard	USB standard	USB standard

TECHNICAL SPECIFICATIONS FOR SL6 AUTOMATIONS

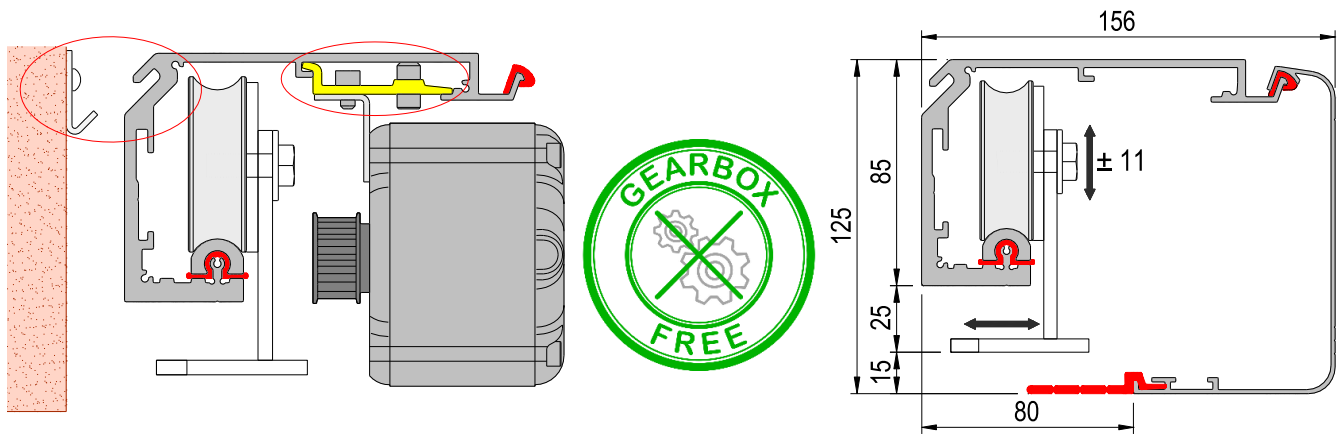

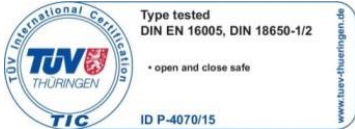
Series	SL6A	SL6E	SL6H
Model	ADVANCED	EMERGENCY	HEAVY
Use	Sliding automatic doors	Sliding automatic doors for escape routes and emergency exits	Heavy sliding automatic doors
Type approval			
Dimensions	125 x 156 x 6600 mm	125 x 156 x 6600 mm	125 x 156 x 6600 mm
Max. load	140 kg 1 wing 2x120 kg 2 wings	140 kg 1 wing 2x120 kg 2 wings	180 kg 1 wing 2x150 kg 2 wings
Max. speed	0.8 m/s 1 wing 1.6 m/s 2 wings	0.8 m/s 1 wing 1.6 m/s 2 wings	0.6 m/s 1 wing 1.2 m/s 2 wings
Service class Intermittence	Continuous operation S3 = 100%	Continuous operation S3 = 100%	Intense operation S3 = 60%
Internal durability test			
Power supply	100–240 V 50/60 Hz	100–240 V 50/60 Hz	100–240 V 50/60 Hz
Power	70W	70W	70W
Stand-by	10W	10W	10W
Rated load	150 N	150 N	150 N
Degree of protection	IP 20	IP 20	IP 20
Operating temperature	 -15 °C  +50 °C	 -15 °C  +50 °C	 -15 °C  +50 °C
Parameter adjustment	Buttons and display	Buttons and display	Buttons and display
Accessory output	12 VDC (1 A max)	12 VDC (1 A max)	12 VDC (1 A max)
Firmware update	USB standard	USB standard	USB standard



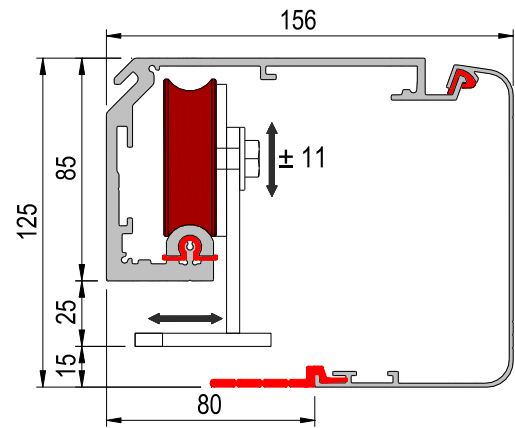
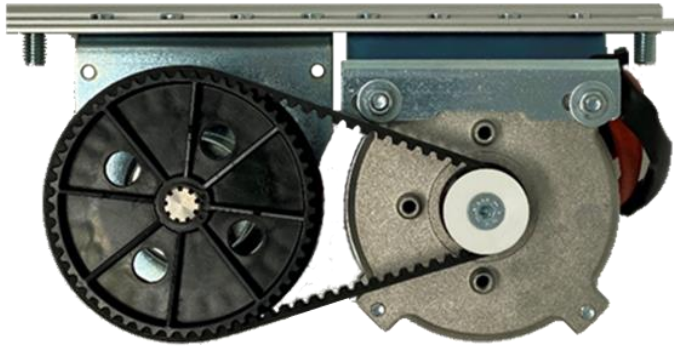



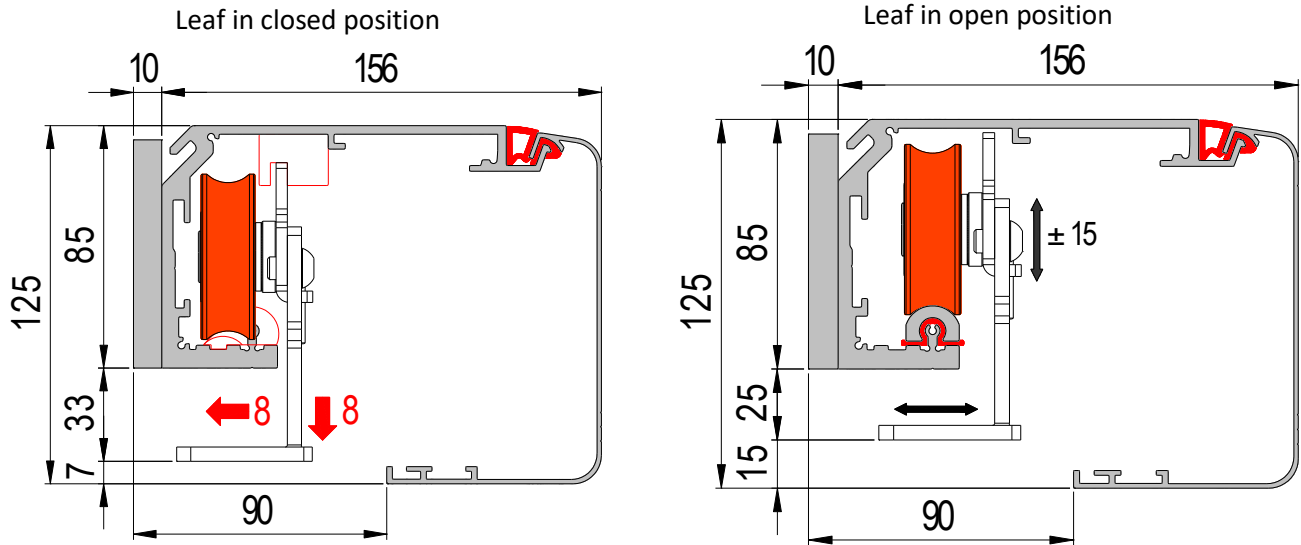

TECHNICAL SPECIFICATIONS FOR SL6B AUTOMATIONS



Series	SL6B
Model	BIG
Use	Heavy sliding automatic doors
Reference standards	EN 16005
Dimensions	125 x 156 x 6600 mm
Max. load	400 kg 1 wing 2x250 kg 2 wings
Max. speed	0.3 m/s 1 wing 0.6 m/s 2 wings
Service class Intermittence	Intense operation S3 = 60%
Internal durability test	
Power supply	100–240 V 50/60 Hz
Rated power	70W
Stand-by	10W
Rated load	350 N
Degree of protection	IP 20
Operating temperature	-15 °C +50 °C
Parameter adjustment	Buttons and display
Accessory output	12 VDC (1 A max)
Firmware update	USB standard







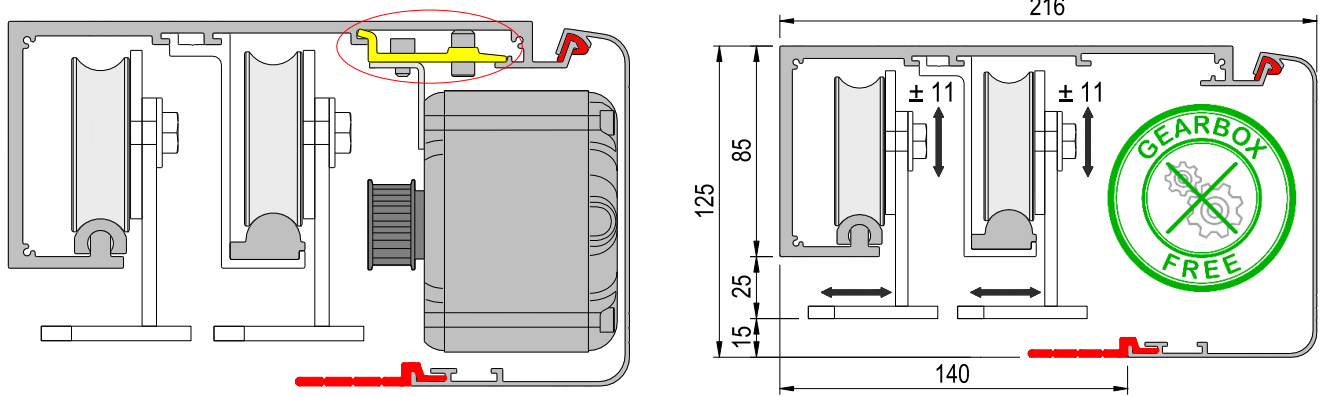

TECHNICAL SPECIFICATIONS FOR SL6HA - SL6HB HERMETIC SLIDING AUTOMATIONS







Series	SL6HA	SL6HB
Model	HERMETIC - ADVANCED	HERMETIC - BIG
Use	Hermetic sliding doors	Heavy hermetic sliding doors
Type approval	 <p>Type tested EN 16005 • open and close safe ID P-4112/19 www.tuev-thueringen.de</p>	 <p>Type tested EN 16005 • open and close safe ID P-4112/19 www.tuev-thueringen.de</p>
Dimensions	125 x (10+156) x 6600 mm	125 x (10+156) x 6600 mm
Max. load	100kg	200 kg
Max. speed	0.8 m/s	0.3 m/s
Service class Intermittence	Intense operation S3 = 60%	Intense operation S3 = 60%
Internal durability test Direct-drive brushless motor with no reduction gear unit	 	
Power supply	100–240 V 50/60 Hz	100–240 V 50/60 Hz
Rated power	70W	70W
Stand-by	10W	10W
Rated load	150 N	350 N
Degree of protection	IP 20	IP 20
Operating temperature	 -15 °C  +50 °C	 -15 °C  +50 °C
Parameter adjustment	Buttons and display	Buttons and display
Accessory output	12 VDC (1 A max)	12 VDC (1 A max)
Firmware update	USB standard	USB standard

TECHNICAL SPECIFICATIONS FOR SLT TELESCOPIC AUTOMATIONS



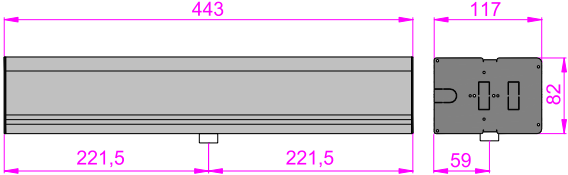

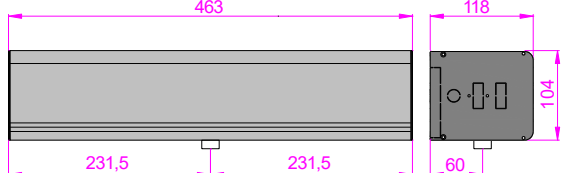

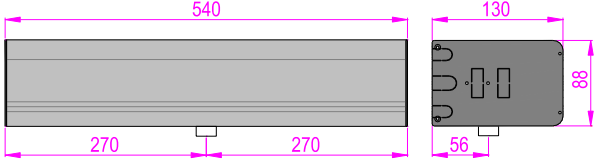

Series	SLTA	SLTE
Model	TELESCOPIC - ADVANCED	TELESCOPIC - EMERGENCY
Use	Telescopic sliding doors	Telescopic sliding doors for escape routes and emergency exits
Type approval	 <p>Type tested DIN EN 16005, DIN 18650-1/2</p> <ul style="list-style-type: none"> • open and close safe <p>ID P-4081/16</p>	 <p>Type tested DIN EN 16005, DIN 18650-1/2, AutSchR</p> <ul style="list-style-type: none"> • escape route safe • open and close safe <p>ID P-4082/16</p>
Dimensions	125 x 216 x 6600 mm	125 x 216 x 6600 mm
Max. load	2x100 kg 2 wings 4x70 kg 4 wings	2x100 kg 2 wings 4x70 kg 4 wings
Max. speed	0.8 m/s 2 wings 1.6 m/s 4 wings	0.8 m/s 2 wings 1.6 m/s 4 wings
Service class Intermittence	Continuous operation S3 = 100%	Continuous operation S3 = 100%
Internal durability test		
Power supply	100–240 V 50/60 Hz	100–240 V 50/60 Hz
Rated power	70W	70W
Stand-by	10W	10W
Rated load	150 N	150 N
Degree of protection	IP 20	IP 20
Operating temperature	 -15 °C  +50 °C	 -15 °C  +50 °C
Parameter adjustment	Buttons and display	Buttons and display
Accessory output	12 VDC (1 A max)	12 VDC (1 A max)
Firmware update	USB standard	USB standard

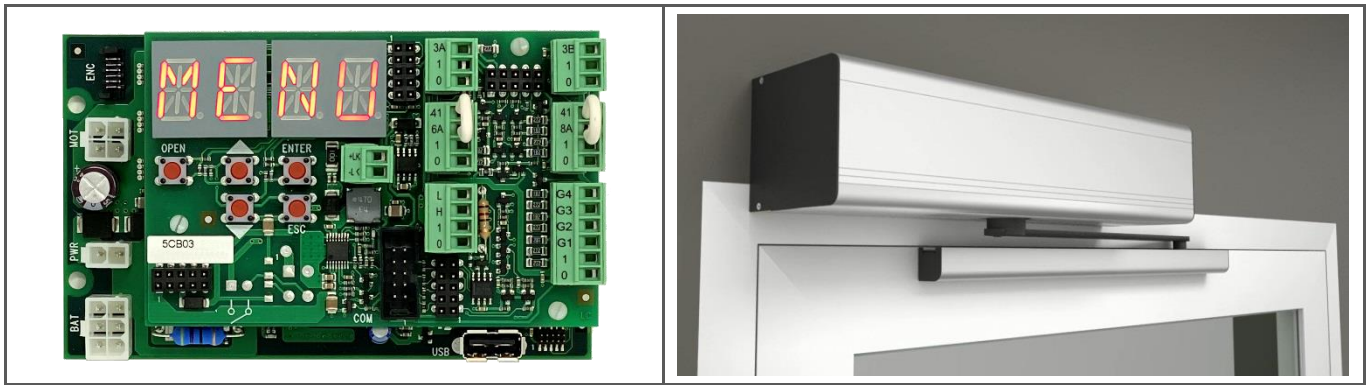
RANGE OF SWING AUTOMATIONS

SWING AUTOMATIONS	MAX WEIGHT	SERVICE CLASS INTERMITTENCE	DIMENSIONS
SW2 LIGHT	1x200 kg	Continuous operation S3 = 100% 	
SW5 HEAVY	1x300 kg	Continuous operation S3 = 100% 	
SW80S SPRING SW80S1 LIGHT SPRING	1x300 kg 1x300 kg	Continuous operation S3 = 100% S3 = 100% 	

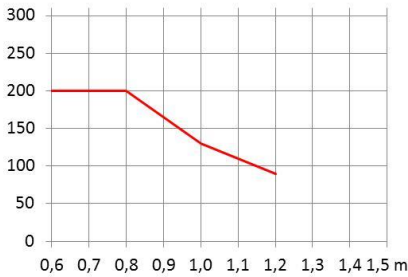
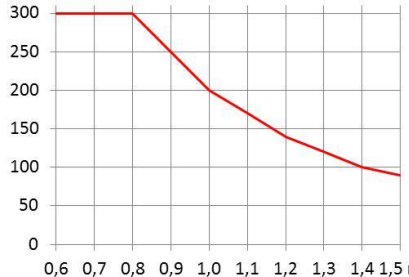
TECHNICAL SPECIFICATIONS FOR SWING AUTOMATIONS



Series	SW2	SW5
Model	LIGHT	HEAVY
Use	Automatic swing doors for internal use	Automatic swing doors
Type approval		
Dimensions	82 x 117 x 443 mm	104 x 118 x 463 mm
Max. load	<p>200 kg x 0.8 m</p> 	<p>300 kg x 0.8 m</p> 
Operating time	2 – 6 s	2 – 6 s
Service class Intermittence	Continuous operation S3 = 100%	Continuous operation S3 = 100%
Internal durability test		
Power supply	100–240 V 50/60 Hz	100–240 V 50/60 Hz
Power	40 W	70 W
Stand-by	8 W	8 W
Rated load	20 Nm	40 Nm
Degree of protection	IP 20	IP 20
Operating temperature		
Parameter adjustment	Buttons and display	Buttons and display
Accessory output	12 Vdc (1 A max)	12 Vdc (1 A max)
Firmware update	USB standard	USB standard

TECHNICAL SPECIFICATIONS FOR SWING AUTOMATIONS WITH SPRING

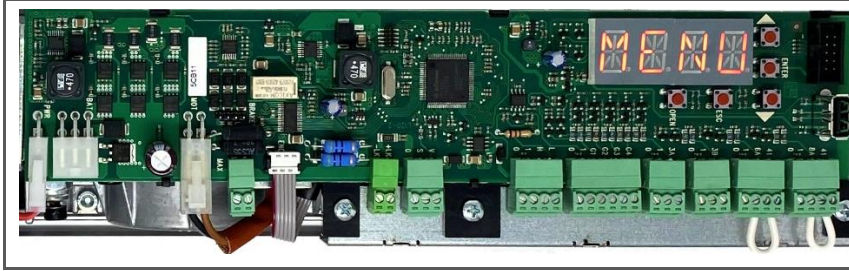

Series	SW80S	SW80S1
Model	SPRING	LIGHT SPRING
Use	Automatic swing doors with self-closing spring	Automatic swing doors with self-closing spring, with easy manual handling
Reference standards	EN 16005 EN 1154 (closing force: EN4 ÷ EN6) EN 1634-1 (fire resistance: 120 min)	EN 16005 EN 1154 (closing force: EN2 ÷ EN4) EN 1634-1 (fire resistance: 120 min)
Type approval		
Dimensions	88 x 130 x 540 mm	88 x 130 x 540 mm
Max. load	300 kg x 0,8 m 	300 kg x 0,8 m
Operating time	2 – 6 s	2 – 6 s
Service class Intermittence	Continuous operation S3 = 100%	Continuous operation S3 = 100%
Internal durability test		
Power supply	100–240 V 50/60 Hz	100–240 V 50/60 Hz
Power	70 W	70 W
Stand-by	3 W	3 W
Rated load	40 Nm	40 Nm
Degree of protection	IP 20	IP 20
Operating temperature		
Parameter adjustment	Buttons and display	Buttons and display
Programmable terminals	4 (G1, G2, G3, G4)	4 (G1, G2, G3, G4)
Accessory output	12 Vdc (1 A max)	12 Vdc (1 A max)
Power output for electric locks	12 Vdc (1A max)/24 Vdc (0,5 A max)	12 Vdc (1A max)/24 Vdc (0,5 A max)
Firmware update	USB standard	USB standard

SF30 ALUMINUM PROFILE SYSTEM FOR AUTOMATIC SLIDING DOORS

This new series of profiles meets the safety requirements of the European EN16005 standard.

The mechanical operations necessary for the assembly of the whole system of sliding wings + fixed side walls + frames profiles are simplified to the maximum obtaining an excellent final result both in terms of solidity of the system and aesthetic appeal studied to the smallest detail.

The whole system is certified EN16005 by the German TÜV THÜRINGEN , after having carried out a million cycles on our sliding automations and having passed all the required tests.

Automatic sliding doors

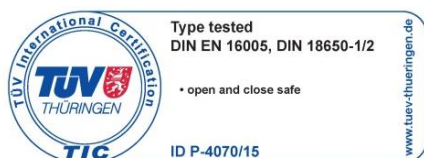

Automatic sliding doors for emergency exits



Telescopic automatic doors

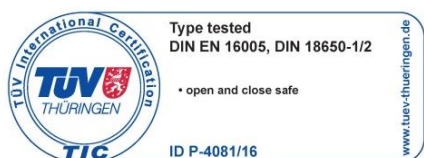

Telescopic automatic doors for emergency exits



The SF30 frame system for automatic sliding and telescopic doors, with 30 mm thickness, is designed to host **two types of glasses**:

- safety glass from **8 to 10 mm** thickness;
- thermal glass from **20 to 22 mm** thickness.

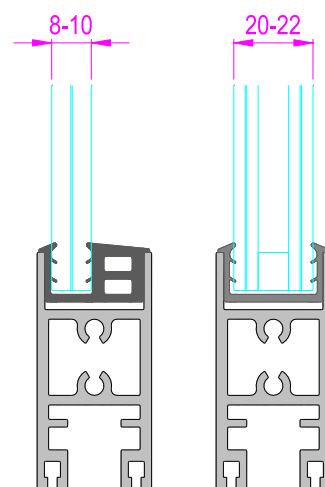

There are two sales options .

- **Sale in SET:** Profiles, gaskets, brushes and screws already set for various types of sliding doors for those who need to develop one single door buying only the necessary material, without any warehouse stock.
- **Sale in KIT:** Aluminium profiles in bars, gaskets and brushes in rolls and kits of screws , for those who need to install continuously sliding doors and can therefore optimize their consumptions and costs.

FACE has also developed a technical/commercial configurator that enables to obtain in a fast and precise way the following output data by easily inserting the sizes of the required door.

- The complete list of the items to be ordered, with relative quantities and prices.
- The list with cutting measures for aluminium profiles and gaskets.
- The list of the types of glasses with relative dimensions and weights.

SF30 AUTOMATIC SLIDING DOORS - VERTICAL DRAWINGS

Automatic door with 2 sliding leaves

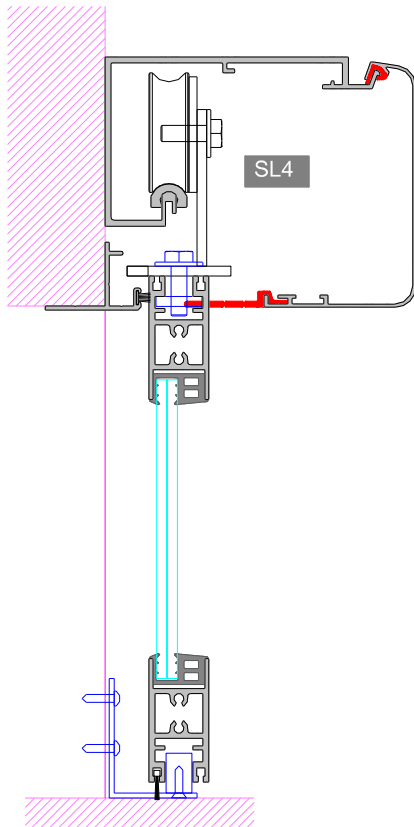

Automatic door with 2 sliding leaves + 2 side walls

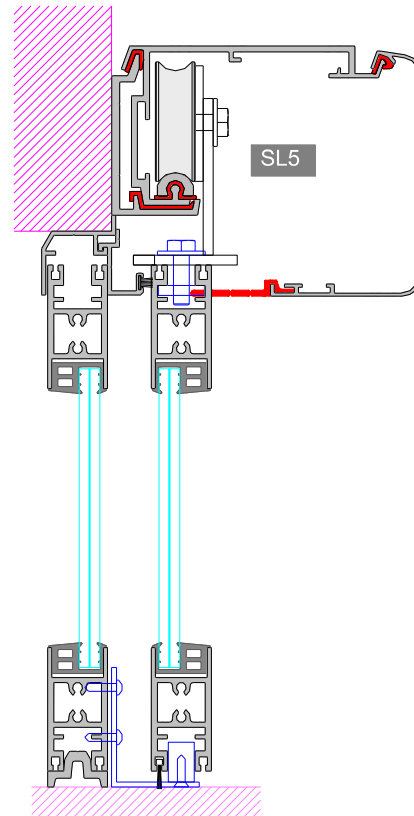

Telescopic automatic door with 4 sliding leaves

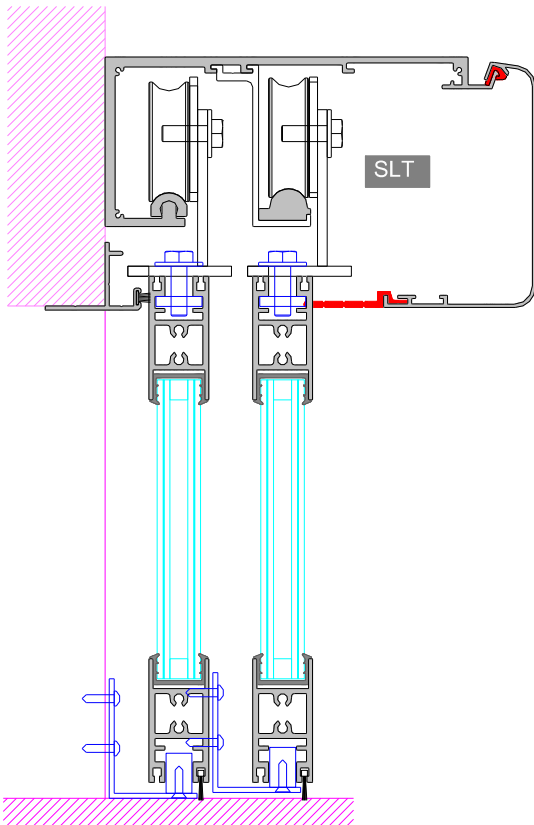

Telescopic automatic door with 4 sliding leaves + 2 side walls

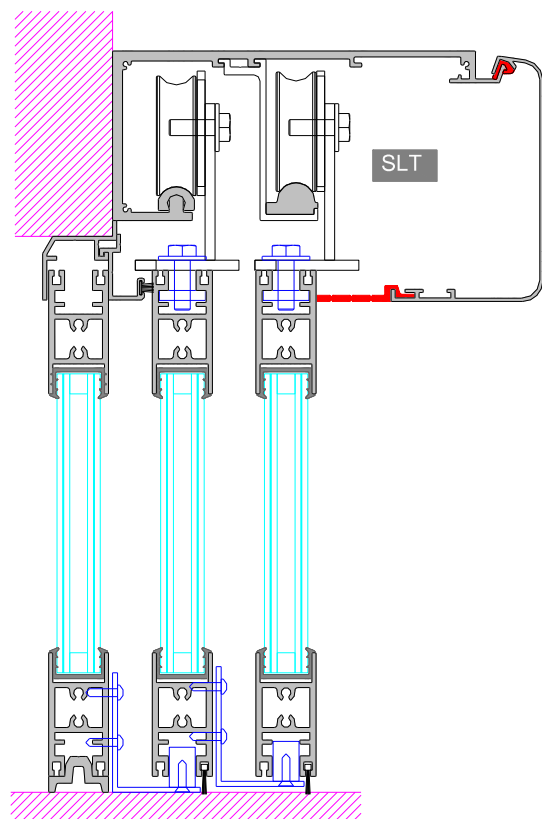

SF30 AUTOMATIC SLIDING DOORS - HORIZONTAL DRAWINGS

Automatic door with 2 sliding leaves

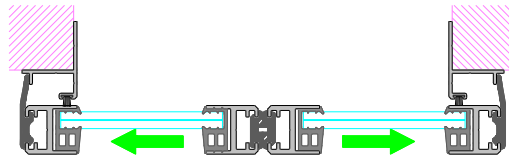

Automatic door with 2 sliding leaves + 2 side walls

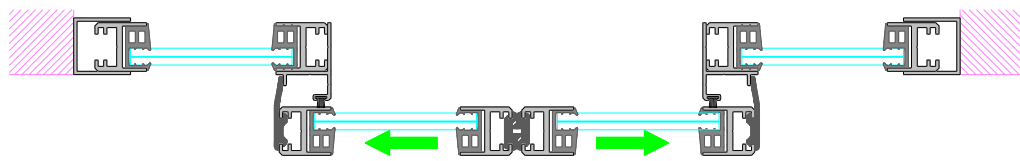

Telescopic automatic door with 4 sliding leaves

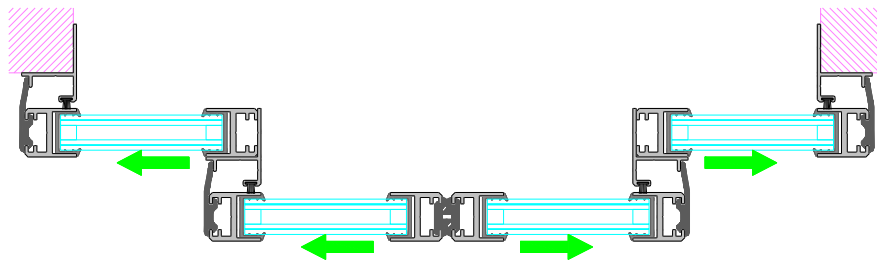

Telescopic automatic door with 4 sliding leaves + 2 side walls

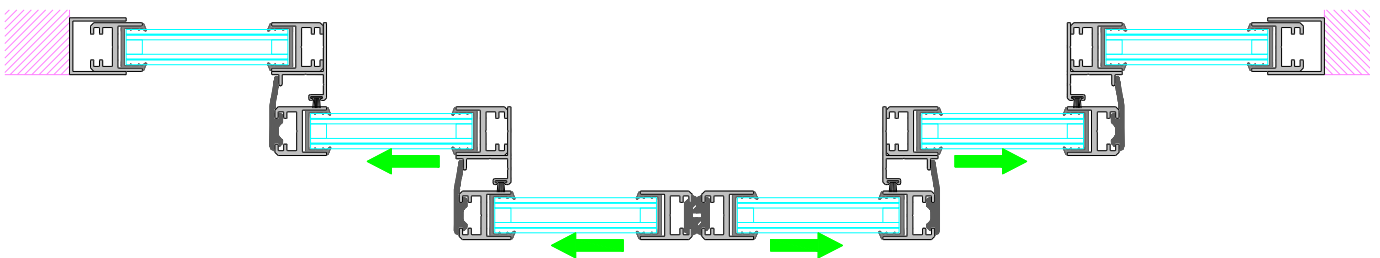





INNOVATE TO SIMPLIFY RESPECTING THE PLANET



All technical and commercial documents are available in the Download area of the website www.facespa.it.



[HOME](#)

[PRODUCTS](#)

[DOWNLOAD](#)

[VIDEO](#)

[CONTACTS](#)

Language: 



Follow us on:

